

## Transduction Chamber - P0007

- mechanical, antimagnetic, sea water resistant, maintenance free
- shock and vibration resistant

**Applications** Shipbuilding, naval shipbuilding, heating and air-conditioning technology, environmental and process technology, plant construction.

**Media** Fluids of low viscosity. (e.g. water)

The Pneumatic Tank Level System Type 258 continuously measures the tank levels without the need for auxiliary energy. The system is a closed, pressurized system. The device is applicable for tanks between 0,5m and 16m height.

The transduction chamber is filled with the tank fluid and transmits the hydrostatic pressure to the indicator gauge using the transmission line. Height differences between the indicator gauge and the transduction chamber do not influence the measuring result. The transduction chamber must not be separated from the transmission line and the indicator gauge.

Specifications		
transmission line position	side	
mounting position	90°	
	*other options on request	
weather protection	IP67 as per DIN EN 60529	
short time overpressure	15 bar	
Technical Limitations		
	min	max
tank height	0,5m	16m
operating temperature	-20°C	
transmission line length		
tank height 0,5m-2m:	5m	
tank height: 2m-16m:	16m	
temperature influence	±0,4% FSO/10K	
weight	2,2 kg	
Additional Options		
free from oil and grease	yes/no	
suitable for O <sub>2</sub> application	yes/no	
suitable for fuel cells	yes/no	
with bulkhead pipe fitting	yes/no	
Materials		
casing	stainless steel	
wetted parts	copper alloys	

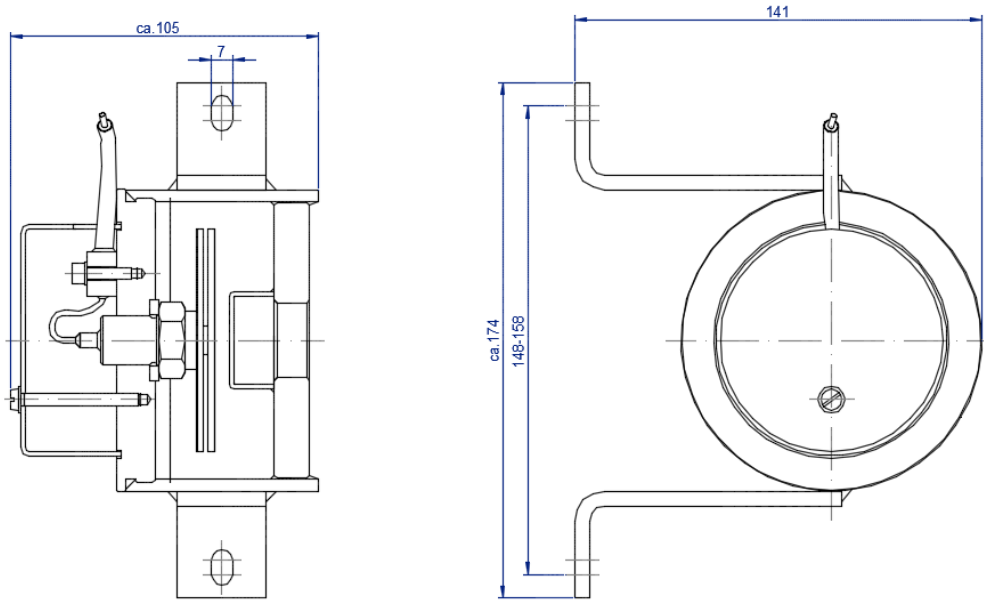

Dimensions  
(mm)

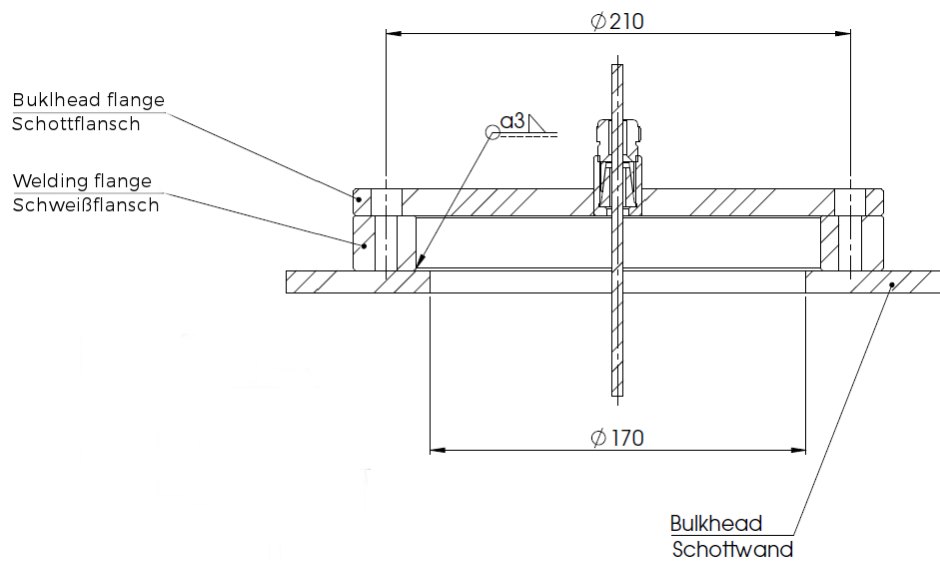

Dimensions  
bulkhead  
flange  
(mm)

### Colours

casing	black	RAL 9005
	grey	RAL 7037
	unvarnished	
	*more colour options on enquiry	