

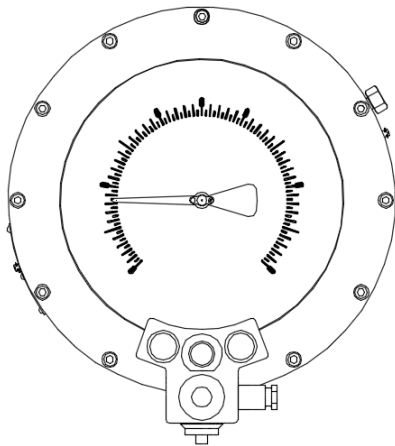











Tiefenmesser - M0075

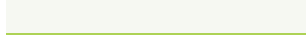

- Nenngröße: 250
- amagnetisch, wartungsfrei
- schock- und rüttelsicher nach BV 043/044
- mit hinterem Befestigungsrand
- mit Entlüftungsschraube
- mit Skalenbeleuchtung

Einsatzbereiche Schiffbau, Marineschiffbau

Messmedien Wasser, Seewasser

Ausführungen			
Messgliedtyp	Rohrfeder		
Anschluss	G1/2"A, unten		
Genauigkeitsklasse	0,6 nach EN 837-1		
Schutzart	IP 54 nach DIN EN 60529		
Elektrische Daten	24Vdc, max 0,16A / 3,84W		
Kurzzeitige Belastung	1,3 x Skalenwert		
Technische Grenzwerte			
Betriebstemperatur	min	max	
Temperaturverhalten	-20°C	+50°C	
Gewicht	9,6kg	±0,4% FSO / 10K	
Material			
Gehäuse	Aluminium		
Mediumberührte Teile	Kupferlegierungen		
Sichtscheibe	Sicherheitsglas		
Farben			
Gehäuse	Schwarz	RAL 9005	
	Grau	RAL 7037	
Skalengrund	Weiß	RAL 9003	
	Schwarz	RAL 9005	
Skalenbeschriftung	Leuchtfarbe	UVG 75 Grün	
	Gelb	RAL 1021	
	Weiß	RAL 9003	
Zeigerfarbe	Leuchtfarbe	UVG 75 Grün	
	Schwarz	RAL 9005	
	Schwarz	RAL 9005	
	Gelb	RAL 1021	
	Leuchtfarbe	UVG 75 Grün	
*weitere Farben auf Anfrage.			

